

Market launch presentation

Hawa Junior 100 – performance guarantee

Hawa Junior 80/100 wood

September
2021



Design for everyone. For tomorrow.

The quality creates trust. The performance guarantee provides security.
Only available with the new Hawa Junior 100.

The campaign at a glance

Hawa Junior 100 with performance guarantee



We will keep you up to date!

Please do not hesitate to contact us if you have any questions:
marketing@hawa.com

Hawa Junior 80/100 wood Innovations

News for trade
partners

September 2021



What does the world of tomorrow look like?

A global view of the future

How is the world changing demographically?



>30% of the population will be 65+ years old in 2050

What will cities and regions look like?



>68% of the population will living in urban regions in 2050.

How is our lifestyle developing?

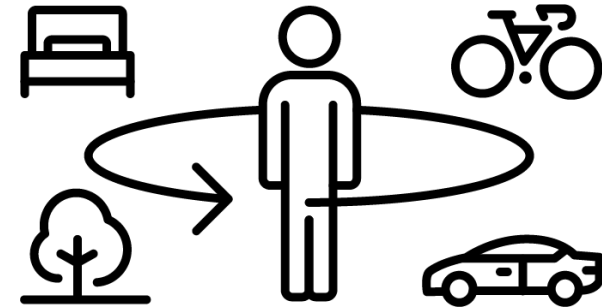

>30% of the population will be living in new living & life concepts in 2050.



The population is becoming older, and accessibility is becoming a must-have requirement.

Hawa Junior 100 with SoftMove is fully accessible and can be operated with a minimal amount of force.





Compact construction and new forms of living require flexible and space-saving room solutions.

Hawa Junior makes optimum use of living space.

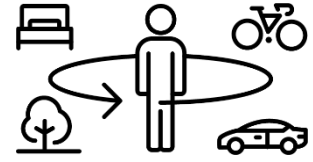

Hygge/Lagom Lifestyle
– natural materials and
puristic designs are
asserting themselves.

**Hawa Junior is intended
for high-quality, puristic
interior design.**

Sliding solutions from Hawa fulfill the requirements of tomorrow.



Silver Society

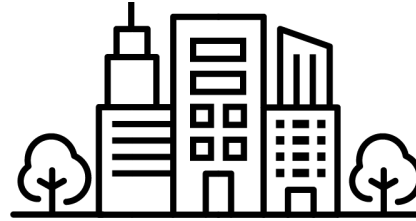

Urbanization

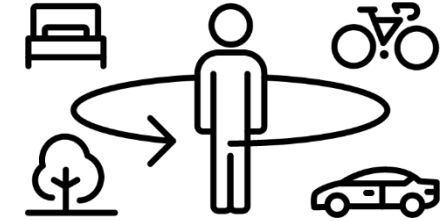

Neo-ecology

Hawa Junior



Increased demand for comfort and accessibility



Flexible room concepts require smart/variable solutions



High-density construction requires more efficient use of space

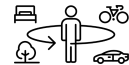

Design trends – natural materials, clear shapes, wood

Comfort and accessibility

For new customer groups

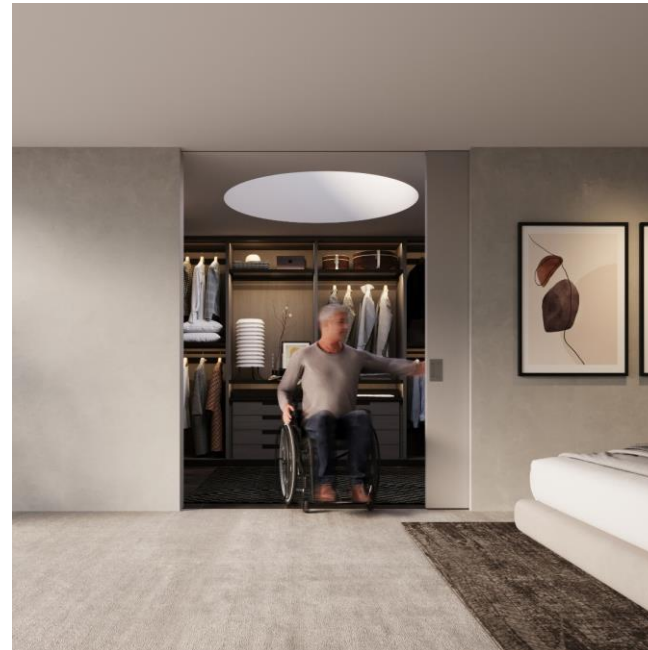

Hawa Junior 100

New products



System with soft closing at two sides from **door width of just 800 mm**

Four different installation situations for additional flexibility in the room concept



Continuous, convenient adjustment of doors for ease of installation

Quick, tool-less installation and removal of the door

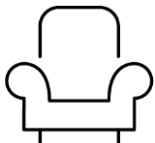

Soft closing and full accessibility

combined with new SoftMove, opening force **<22 N**

Doors are **silently** braked and pulled closed



Invisible technology integrated in the running track makes high-quality design possible



New system tested for 100,000 cycles, which corresponds to the lifetime of a door, approx. 25 years
(meets standard: DIN EN1527; 2019)

Hawa Junior 80

New products



Four different installation situations for additional flexibility in the room concept



Continuously variable, convenient door adjustment

Quick, tool-less installation and removal of the door



Soft braking of the door with **Softstop** Junior 80/100



Invisible technology integrated in the running track makes high-quality design possible



Well-tries system, running gear tested for 100,000 cycles, ideal for heavily used doors

Hawa Junior 80/100

Family installation examples

Hawa Junior 100 Z

Hawa Junior 80 Z

Hawa Junior 80 B / B Pocket

Hawa Junior 100 B / B Pocket

Hawa Junior Pocket
80 B/Z
100 B/Z

Wall mounting

Ceiling mounting

Ceiling mounting

Ceiling mounting

Wall mounting

Assembly set
for wall pockets

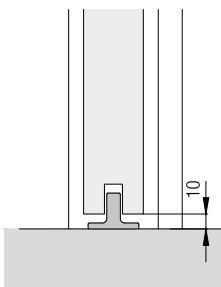
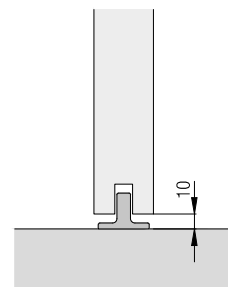
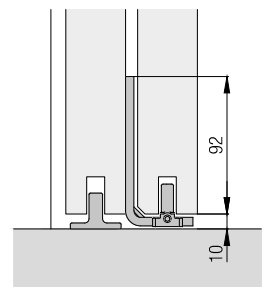
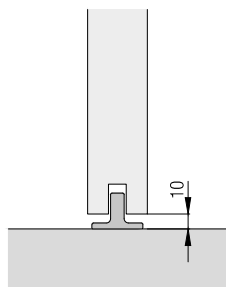
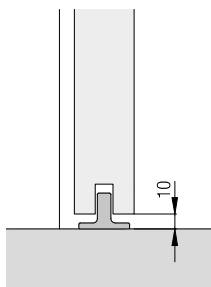
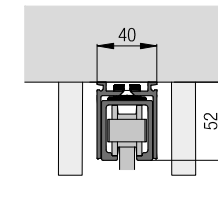
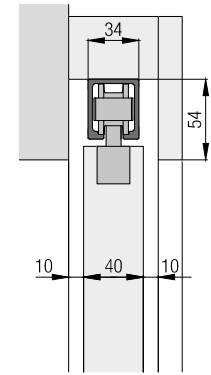
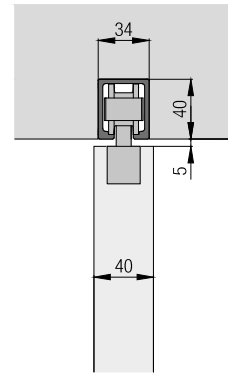
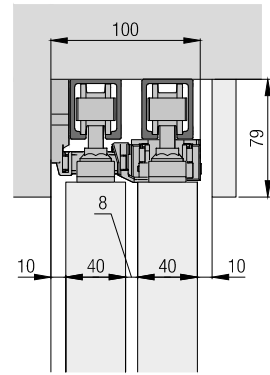
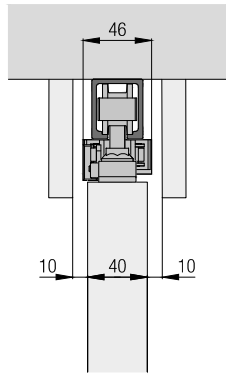
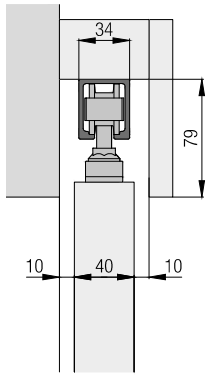

Wall mounting

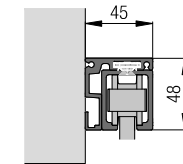

Single-leaf

Symmetric

Telescopic

Single-leaf

Wall pocket

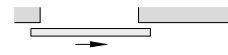
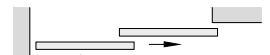
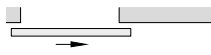

Identical running track
for Hawa Junior 80 and
Hawa Junior 100!

Highlights

for users and architects



SoftMove 100 for **Hawa Junior 100**

- Soft closing system which fulfils all of the requirements for **accessibility** with its low operating force of **<22 N**

Ceiling integration for **Hawa Junior 80/100**

- Discreet, concealed system
- Dream of a modest and elegant design

New designs for **Hawa Junior 80/100**

- Wall mounting with integrated panels and high quality side ends

Softstop for **Hawa Junior 80/100**

- Gentle stopping of the door

Highlights

for processing companies

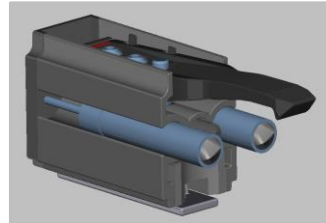
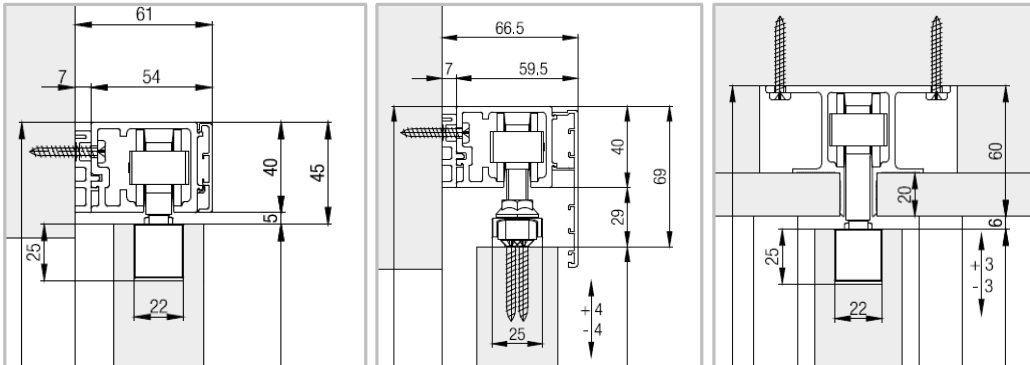
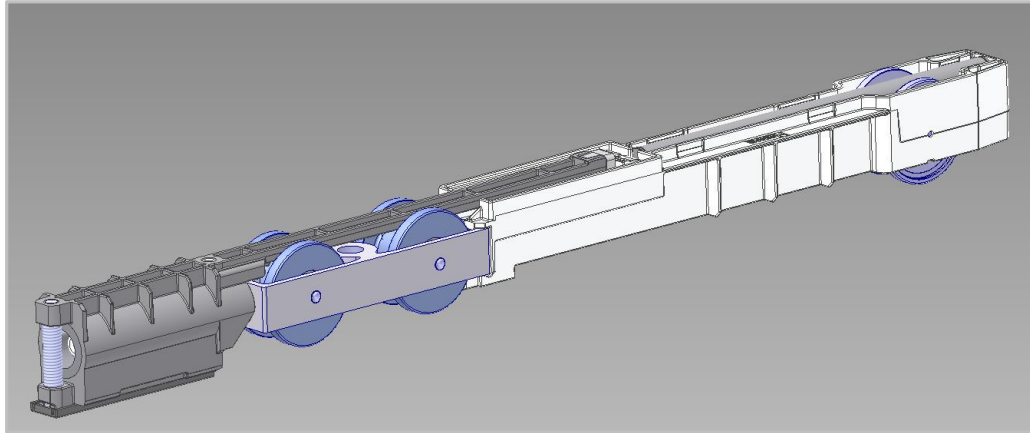

- 1 SoftMove 100 for Hawa Junior 100**
 - Very simple installation with **pre-assembled unit** means efficient and reliable installation.
 - No measuring or processing required
- 2 Integrates solutions for Hawa Junior 80/100**
 - Wall mounting Hawa Junior Z/B
 - Integrated clip-on panels
 - Ceiling integration Hawa Junior B +20mm
- 3 Softstop for Hawa Junior 80/100**
 - Identical installation to stopper

Highlights Junior 100



for sales partners: Product range design – modular kit – catalogue

Hawa Junior 100 B Pocket







System available from January 2022

1

Set for 1 wooden door up to 100 kg (220 lbs.)

	No.
Hawa Junior 100 B Pocket, for 1 door	30154
Hawa Junior 100 B Pocket, +20 mm (+25/32"), for 1 door	30155

Set consisting of:



	30154	30155	No.
 Suspension profile, with plate, with suspension bolt M10, wall pocket installation	1		24323
 Suspension profile, plate with screw M10	1		24246
 Bottom guide, zero tolerance, groove width 10 mm, plastic, black	1	1	25369
 Screw-on rubber door stop	1	1	10629
 Locking wrench to suspension	1	1	10778
 Suspension profile, plate, with 20 mm longer screw M10, ceiling integration		1	24846
 Suspension profile, plate with 20 mm longer screw M10, for Pocket		1	26003

2

Set for 1 wooden door, with running gears and magnetic soft closing mechanism



	No.
Hawa Junior 100, 2 running gears, for 1 door	30064
Hawa Junior 100, 1 running gear, 1 SoftMove 100 with running gear and stopper, for 1 door	30149
Hawa Junior 100, 2 SoftMove 100 with running gear and stopper, for 1 door	30150

Set consisting of:

	30064	30149	30150	No.
 Running gear, 2-wheeled, M10, ball bearing	2	1		30137
 Soft close SoftMove 100, with running gear and stopper, premounted		1	2	30044
 Cover cap SoftMove 100, plastic, black		1	2	30053

Accessories for set

3

	No.
 Stopper Hawa Junior 80/100, with adjustable retention spring	30138
 SoftStop Hawa Junior 80/100, with adjustable retention spring	27771
 Spring loaded stopper Hawa Junior 80/100	25370

The Hawa Junior 100 product range is designed as a modular kit:

- Fulfils individual demands for different performance
- The customer determines what he wants and gets exactly this performance
- Product range design minimizes number of stocked parts and stock value
- Higher degree of pre-assembly and release as a unit (soft closing system, running gear), less effort/cost for the processing company

1 Select a system

2 Select: without 1 DES 2 DES

3 Select stopper options

Highlights

for sales partners: Product range design – complete sets









Hawa Junior 100 B Pocket

System available from January 2022









Complete set for 1 wooden door, with 20 mm (25/32") longer suspension bolt and SoftStop

	No.
Hawa Junior 100 B Pocket, with 20 mm longer suspension bolt, 2 SoftStop, for 1 door	30259
Hawa Junior 100 B Pocket, with 20 mm longer suspension bolt, 1 SoftStop and 1 spring loaded stopper, for 1 door	30261

Set consisting of:	30259	30261	No.
 Running gear, 2-wheeled, M10, ball bearing	2	2	30137
 SoftStop Hawa Junior 80/100, with adjustable retention spring	2	1	27771
 Suspension profile, plate, with 20 mm longer screw M10, ceiling integration	1	1	24846
 Suspension profile, plate with 20 mm longer screw M10, for Pocket	1	1	26003
 Bottom guide, zero tolerance, groove width 10 mm, plastic, black	1	1	25369
 Locking wrench to suspension	1	1	10778
 Spring loaded stopper Hawa Junior 80/100	1		25370

Complete set for 1 wooden door, with 20 mm (25/32") longer suspension bolt

	No.
Hawa Junior 100 B Pocket, with 20 mm longer suspension bolt, 1 soft close SoftMove 100 and 1 SoftStop, for 1 door	30264
Hawa Junior 100 B Pocket, with 20 mm longer suspension bolt, 1 soft close SoftMove 100 and 1 spring loaded stopper, for 1 door	30265
Hawa Junior 100 B Pocket, with 20 mm longer suspension bolt, 2 soft close SoftMove 100, for 1 door	30266

Set consisting of:	30264	30265	30266	No.
 Running gear, 2-wheeled, M10, ball bearing	1	1		30137
 Soft close SoftMove 100, with running gear and stopper, premounted	1	1	2	30044
 Cover cap SoftMove 100, plastic, black	1	1	2	30053
 SoftStop Hawa Junior 80/100, with adjustable retention spring	1			27771
 Suspension profile, plate, with 20 mm longer screw M10, ceiling integration	1	1	1	24846
 Suspension profile, plate with 20 mm longer screw M10, for Pocket	1	1	1	26003
 Bottom guide, zero tolerance, groove width 10 mm, plastic, black	1	1	1	25369
 Locking wrench to suspension	1	1	1	10778
 Spring loaded stopper Hawa Junior 80/100	1			25370

Hawa Junior 100 product range with complete sets designed for different versions/options:

- 24 complete sets are now shown in the catalog
- These have been produced for maximum benefit with regard to comfort: Always two-sided stopping by means of combinations of DES, Softstop and spring buffer.

Hawa Junior 80

Product range / pre-information

- A version of the stopper has already been depicted in the “In buildings” catalog
- **Rolling replacement** in 2021 / When the changeover starts, a product information will be produced
 - Track buffer **24497** is being replaced with new track buffer **30138**
 - The functionality and the installation dimensions remain identical
 - Same body as the Softstop

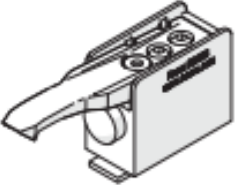
	Track stop, adjustable retaining force	24497
---	--	-------

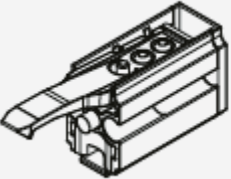
	Stopper Hawa Junior 80/100, with adjustable retention spring	30138
---	--	-------

Advantages

for sales partners

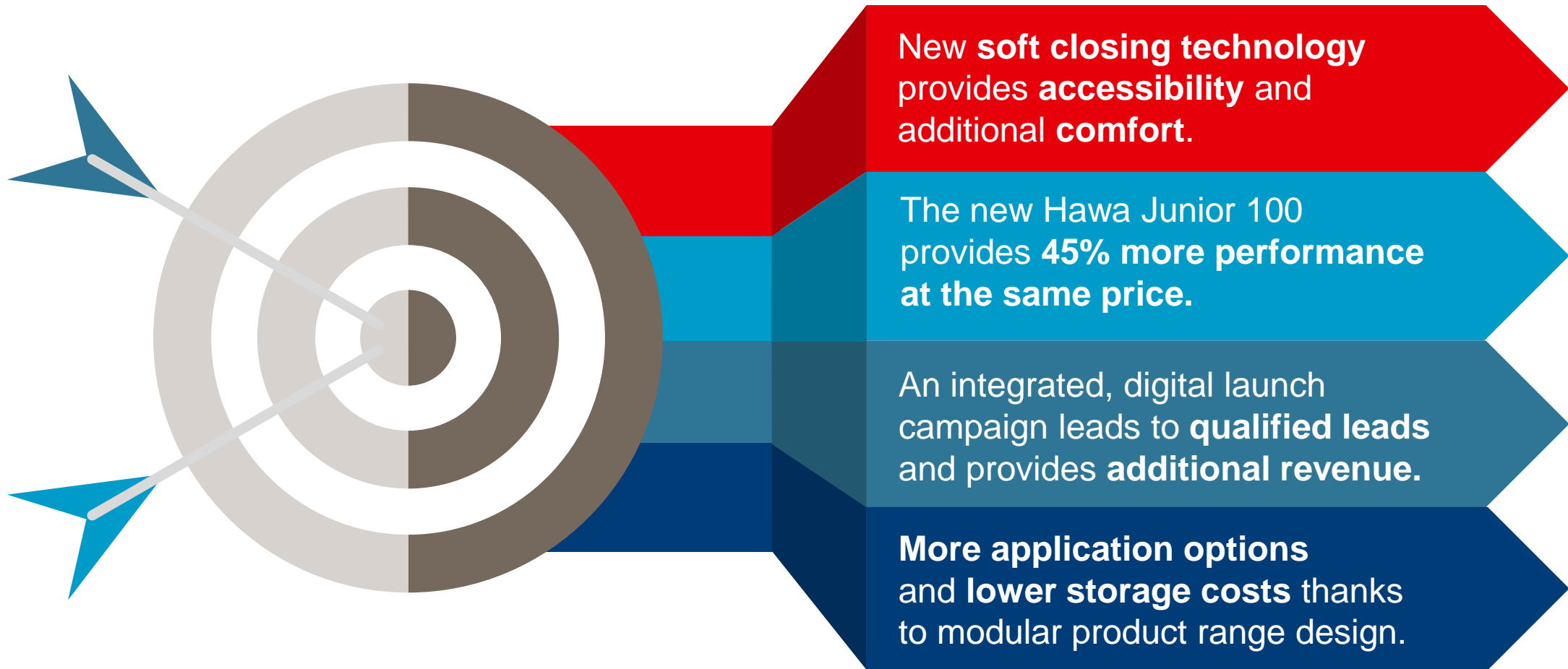

Selling aids

Handmuster/Mock-up

Hawa Junior B 100 +20mm

Art. Nr. 099.0102.126

Preis/Price CHF 300.00

Masse/Size 510 x 285 x 80mm



Hawa Junior sample case 27469: Stocked article / available from November 2021

New top insert for sample case:

Track with Hawa Junior 100 – new stopper

Softstop Hawa Junior 80/100

New running track with DES Hawa Junior 100

Profiles: Wall/ceiling installation with panels

Ceiling integration

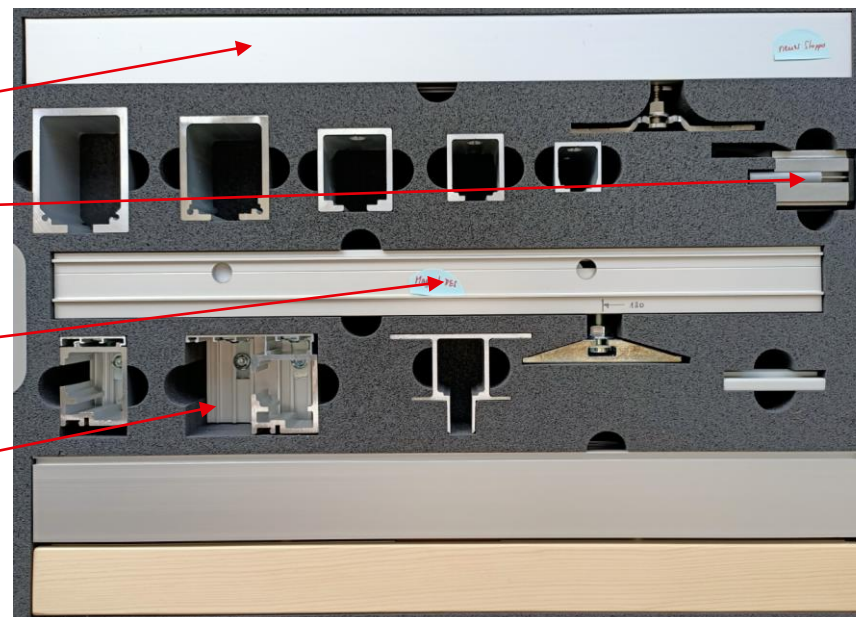

Market launch Hawa Junior 80 extensions

Milestones: New Hawa Junior 80 parts are available from 02/01/2021.

The Hawa Junior 80 catalog pages have been enabled (new profiles, Softstop)

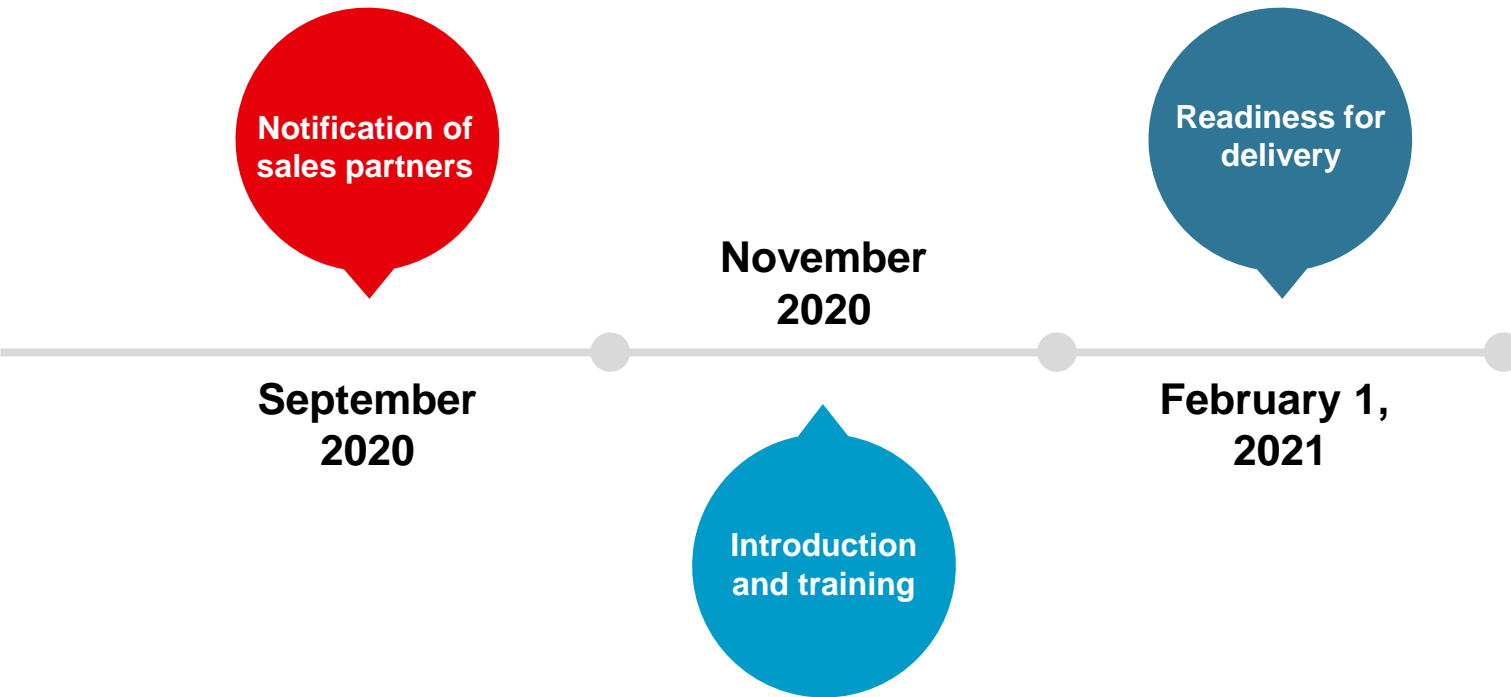

Market launch Hawa Junior 100

Milestones

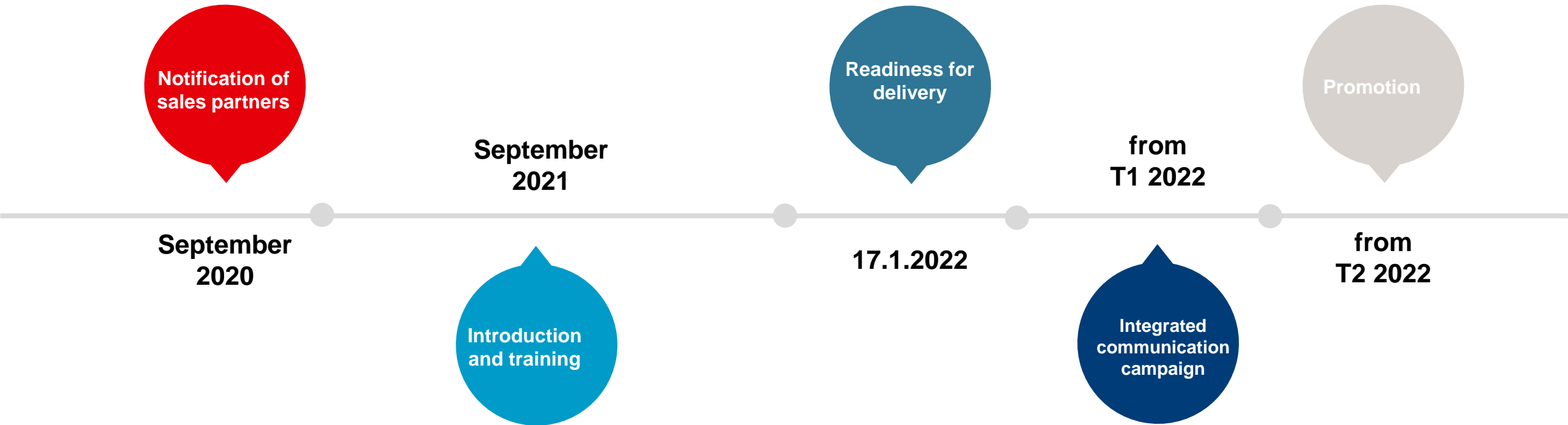

Hawa Junior 80/100 wood

Innovations